



Octagonal Pole Spigot Arm - Flange Mounted

Technical Specification

APPLICATION

Street lighting column with spigot arm has many applications ranging from main roads, residential suburbs, commercial developments, parking areas, pathways and more.

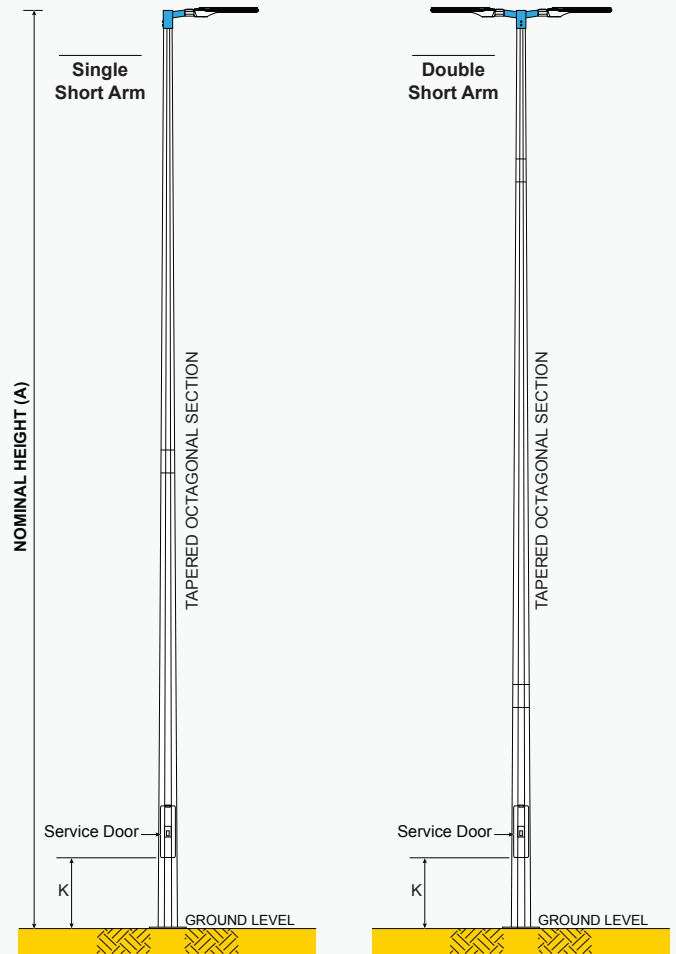
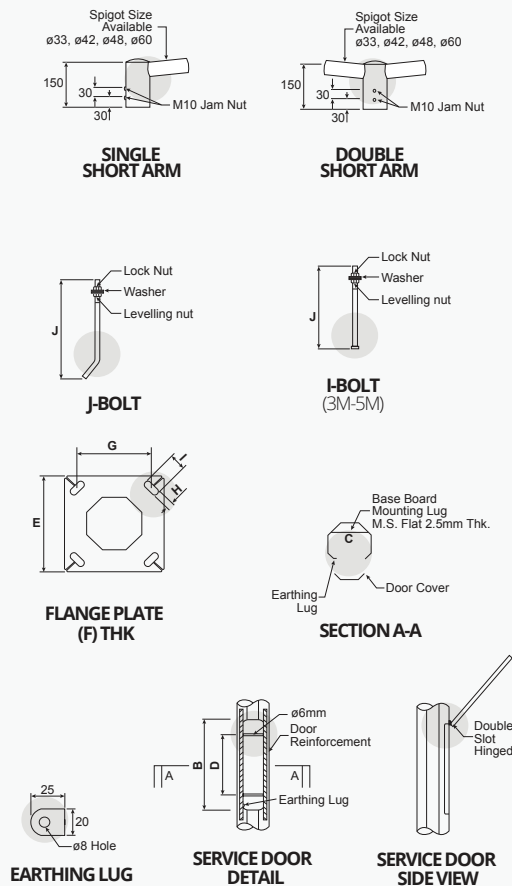

* Option
- Fiber Service Door : 490mm (H) x 185mm (W)

NOMINAL HEIGHT (A)	B	C	D	EX (F) THK.	G X H X I	J	GRD. LVL. to SRVC. DOOR (K)
3M	350mm	90mm	150mm	250 x 9mm	195 x 20 x 44mm	$\phi 16 \times 280(L)$ mm	305mm
4M	350mm	90mm	150mm	250 x 9mm	195 x 20 x 44mm	$\phi 16 \times 280(L)$ mm	305mm
5M	350mm	90mm	150mm	250 x 9mm	195 x 20 x 44mm	$\phi 16 \times 280(L)$ mm	305mm
6M	450mm	100 mm	300mm	300 x 12mm	220 x 26 x 53mm	$\phi 20 \times 450(L)$ mm	305mm
7M	450mm	100mm	300mm	300 x 12mm	220 x 26 x 53mm	$\phi 20 \times 450(L)$ mm	305mm
8M	450mm	120mm	300mm	300 x 12mm	220 x 26 x 53mm	$\phi 20 \times 450(L)$ mm	305mm
9M	450mm	120mm	300mm	300 x 15mm	220 x 26 x 53mm	$\phi 20 \times 450(L)$ mm	610/1850mm
10M	450mm	120mm	300mm	350 x 16mm	260 x 30 x 62mm	$\phi 24 \times 570(L)$ mm	610/1850mm
12M	450mm	120mm	300mm	400 x 18mm	300 x 30 x 67mm	$\phi 24 \times 570(L)$ mm	610/1850mm