

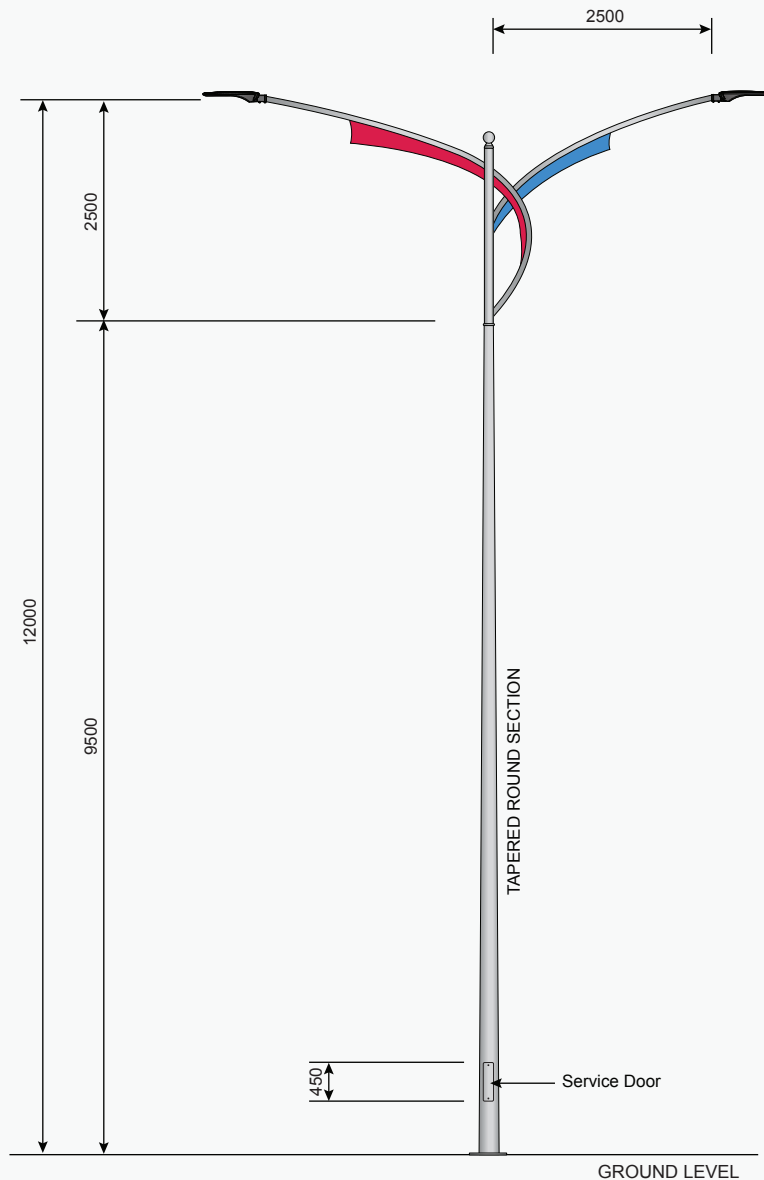

# Arcus Pole - Flange Mounted

## Technical Specification



### DESIGN CONDITIONS

|                  |        |
|------------------|--------|
| Basic Wind Speed | 35 m/s |
|------------------|--------|

### STANDARDS

|                                |                          |
|--------------------------------|--------------------------|
| Pole Design                    | BS EN 40                 |
| Material                       | BS EN 10210, BS EN 10025 |
| Welding (Electric Arc Welding) | BS EN 1011               |
| Galvanizing                    | BS EN 1461:1999          |
| Powder Coating                 | BS EN 13438:2005         |
| QMS                            | ISO 9001:2008            |
| SIRIM Galvanized Test          | >55mm                    |

# Arcus Pole - Flange Mounted

## Technical Specification

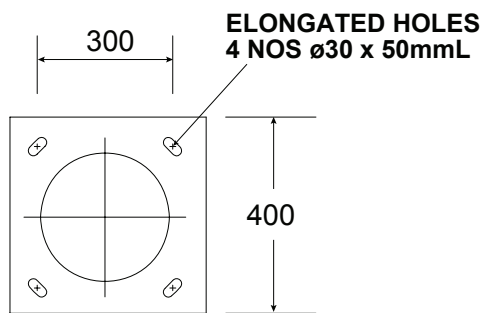
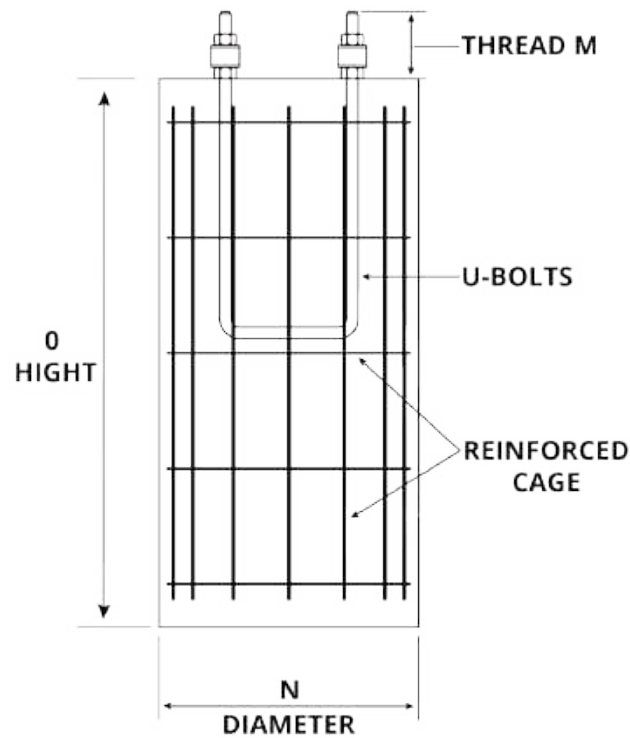

**FLANGE PLATE**

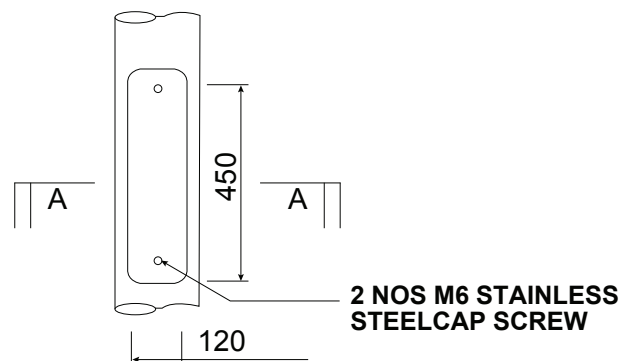

**SERVICE DOOR DETAIL**

