

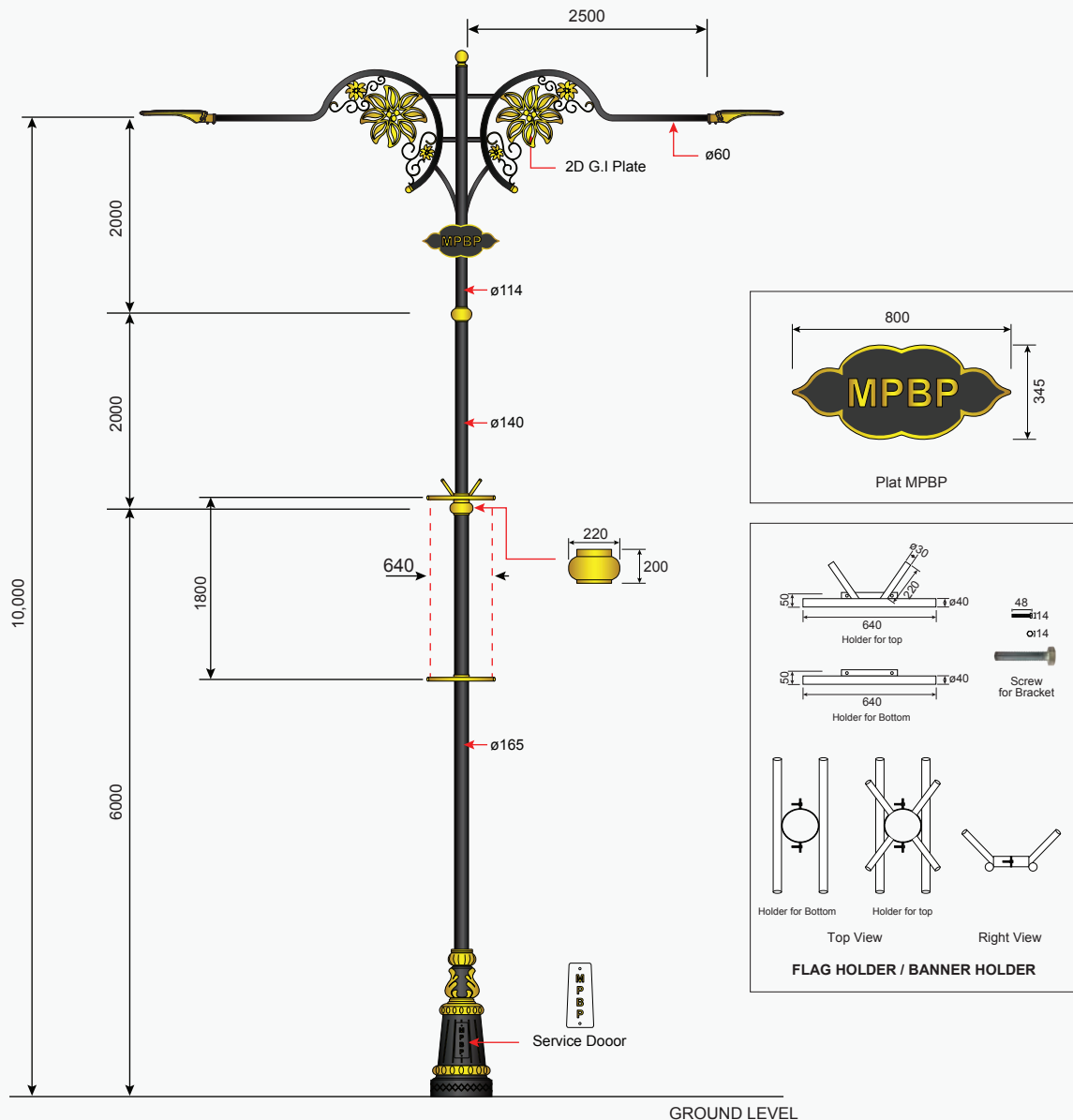

# Grand Promenade Pole - Flange Mounted

## Technical Specification



### DESIGN CONDITIONS

Basic Wind Speed	35 m/s
------------------	--------

### STANDARDS

Pole Design	BS EN 40
Material	BS EN 10210, BS EN 10025
Welding (Electric Arc Welding)	BS EN 1011
Galvanizing	BS EN 1461:1999
Powder Coating	BS EN 13438:2005
QMS	ISO 9001:2008
SIRIM Galvanized Test	>55mm

# Grand Promenade Pole - Flange Mounted

## Technical Specification

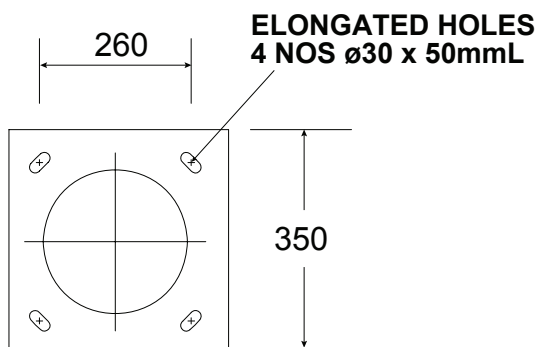
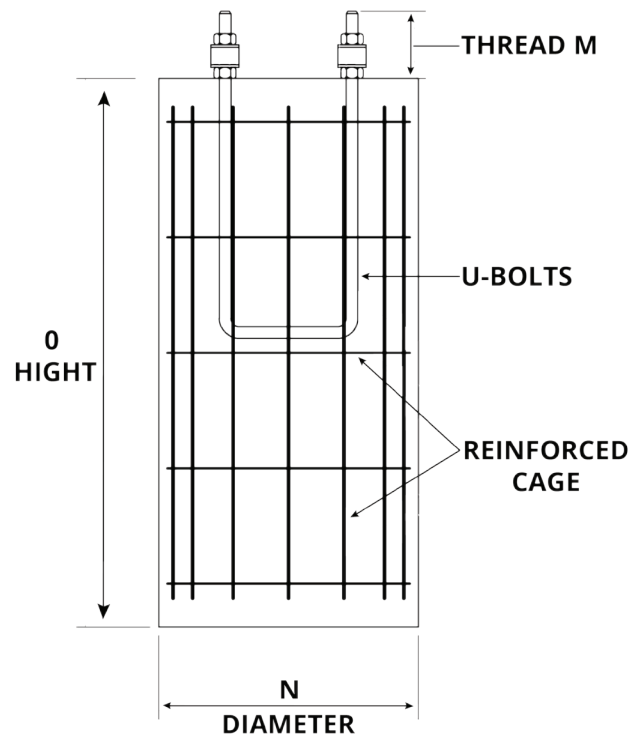

**FLANGE PLATE  
18 MM THICKNESS**

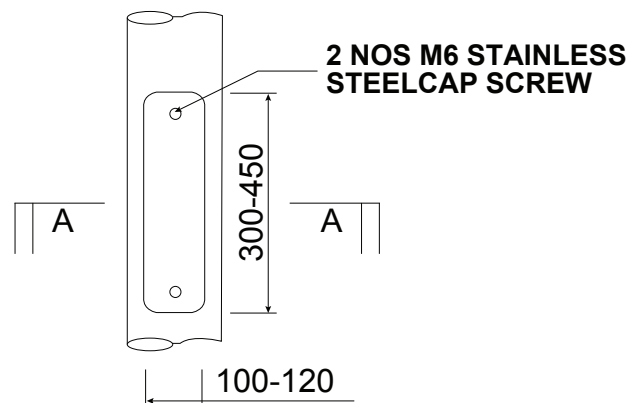

**SERVICE DOOR DETAIL**

